

2-WHEEL

MGB 40-360

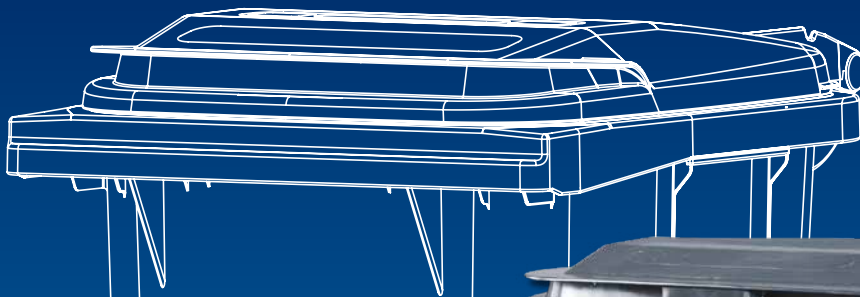

REMARKABLE DIVERSITY



QUALITY IN THE DETAIL

ESE is characterised by distinctive and responsible product development, including environmentally-conscious material selection, appropriate container sizes and long life expectancy.

1. FUNCTIONAL AND CONFORMING TO STANDARDS

ESE always considers the entire logistic and application chain when designing products, including requirements for filling, emptying, handling and health and safety. The MGB fulfils all current European and national standards and is certified in accordance with the highest quality standard worldwide, the RAL-GZ 951/1.

2. ROBUST

Advantages of HDPE material:

- Environmentally friendly
- Long life expectancy
- Can be recycled
- Frost-proof
- Chemical resistant
- High UV light resistance



Lid with lip handle



Lid with bow handle



Handle diameter Ø 27 mm

TECHNICAL DATA

MGB	40	50	60	80	120	140	180	240	260	360
Nominal Volume (l)	40	50	60	80	120	140	180	240	260	360
Weight of container (kg)	10	11	9	9	10	11	13	14	16	19
Max. permissible weight (kg)	40	45	50	50	60	70	90	110	120	170
A Overall height (mm)	930	945	940	940	935	1065	1070	1065	1070	1070
B Overall width (mm)	480	450	445	445	480	480	480	580	650	750
C Overall depth (mm)	554	525	520	520	560	560	745	735	680	805
D Height to upper edge comb (mm)	866	875	872	870	870	1000	1000	990	1000	1000
E Wheel diameter	200	200	200	200	200	200	200	200	200	300

These details are subject to technical changes. For further options, please refer to our accessories brochure. The products contain no substances on the SVHC list of the European Chemicals Agency (ECHA).



3. COMPREHENSIVE STANDARD

- Greater depth of comb receiver ensures optimal lifting security
- Additional honeycomb/diamond structure for safety and maximised life expectancy
- Eight ribs in the chip-nest secure the permanent positioning of the chip
- A smooth internal surface ensures easy emptying and cleaning
- Full rubber tyres on the wheels
- High stability through metal axles made from tempered steel and corrosion protection by electro-galvanising and chroming
- Handles designed to optimise efficient handling and ergonomics
- Colours: 16 standard colours; additional colours on request

MULTIPLE OPTIONS

- 240 I model with third handle
 - Position of handle in the lower front area makes handling easier when used in basements.
- Individual identification:
 - Hot-foil stamping, e.g. council name, council crest
 - Injection embossing of text
 - In-mould labelling on request
- MSTs Diamond system



Diamond MGB 240



Stackable containers

MGB 240, with integrated wheels, can be stacked when completely assembled, saving costs during distribution and allowing for easy storage.

DIMENSIONS

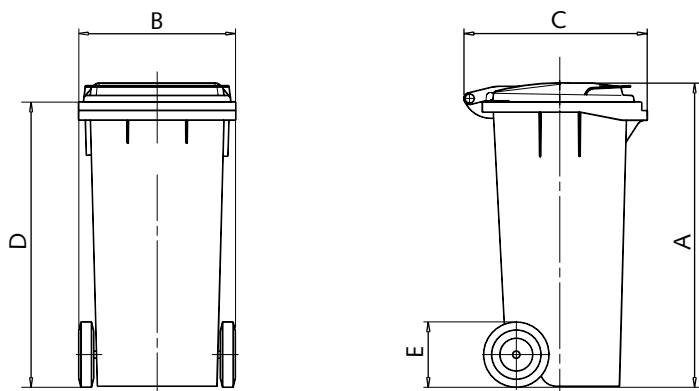

SELECTION OF OPTIONS

- Locking devices
- Various recycling inserts
- Noise reduction
- Identification systems
- Holder for refuse bag
- Foot-operated lid opening
- Solutions for organic waste
- Various designs for anchoring containers